

# Release Notes

## CCURDSCC (WC-AD3224-DS)



<i>Driver</i>	ccurdsc (WC-AD3224-DS)	
<i>Platform</i>	RedHawk Linux® (CentOS/Rocky/RHEL, Ubuntu), Native Ubuntu® and Native Red Hat Enterprise Linux® <sup>1</sup>	
<i>Vendor</i>	Concurrent Real-Time	
<i>Hardware</i>	PCIe 32-Channel Delta Sigma Converter Card (CP-AD3224-DS) (CP-AD3224-DS-10)	
<i>Author</i>	Darius Dubash	
<i>Date</i>	August 8 <sup>th</sup> , 2024	Rev 2024.1



<sup>1</sup> All trademarks are the property of their respective owners

*This page intentionally left blank*

# Table of Contents

<b>1.</b>	<b>INTRODUCTION.....</b>	<b>1</b>
<b>2.</b>	<b>REQUIREMENTS.....</b>	<b>1</b>
<b>3.</b>	<b>DOCUMENTATION.....</b>	<b>2</b>
<b>4.</b>	<b>RUNNING ON NATIVE RED HAT .....</b>	<b>2</b>
4.1.	Support to build 3 <sup>rd</sup> party modules .....	2
4.2.	Support for MSI interrupts .....	2
4.3.	BIOS and Kernel Level Tuning.....	3
<b>5.</b>	<b>RUNNING ON NATIVE UBUNTU .....</b>	<b>3</b>
5.1.	Support to build 3 <sup>rd</sup> party modules .....	3
5.2.	Support for MSI interrupts .....	4
5.3.	Compiling the driver with installed gcc .....	4
5.4.	BIOS and Kernel Level Tuning.....	5
<b>6.</b>	<b>INSTALLATION AND REMOVAL.....</b>	<b>5</b>
6.1.	Hardware Installation .....	5
6.2.	Add Device to Restricted List .....	6
6.3.	Software Installation.....	7
6.4.	Software Removal .....	8
<b>7.</b>	<b>AUTO-LOADING THE DRIVER.....</b>	<b>9</b>
<b>8.</b>	<b>TESTING AND USAGE .....</b>	<b>9</b>
<b>9.</b>	<b>RE-BUILDING THE DRIVER, LIBRARY AND TESTS .....</b>	<b>10</b>
<b>10.</b>	<b>SOFTWARE SUPPORT .....</b>	<b>10</b>
10.1.	Device Configuration.....	10
10.2.	Library Interface .....	11
10.3.	Calibration .....	11
10.4.	Firmware Updates.....	11
10.5.	Debugging.....	12
<b>11.</b>	<b>NOTES AND ERRATA.....</b>	<b>14</b>
<b>APPENDIX A: EXTERNAL CONNECTIONS AND PIN-OUTS .....</b>		<b>15</b>
<b>APPENDIX B: THE 9277 (CP-AD3224-DS) +/- 5 VOLT BOARD.....</b>		<b>16</b>
<b>APPENDIX C: THE 9278 (CP-AD3224-DS-10) +/- 10 VOLT BOARD .....</b>		<b>16</b>

*This page intentionally left blank*

# 1. Introduction

This document assists the user in installing the CCRT-PCIe-DSCC Linux **ccurdsc** driver and related software on the RedHawk OS, Native Ubuntu and Native Red Hat for use with the CCRT-PCIe-DSCC board. The directions in this document supersede all others – they are specific to installing the software on Concurrent Real-Time’s RedHawk and , Native Ubuntu and Native Red Hat systems. Other information provided as part of this release, when it may contradict these directions, should be ignored and these directions should prevail.

Current versions of Native Operating Systems that are supported are:

- 1) Ubuntu 22.04, kernel 6.5, gcc11 & gcc12
- 2) Red Hat RHEL 9.4, kernel 5.14

For additional information on this driver and usage refer to the **ccurdsc** man page.

The CCRT-PCIe-DSCC is a 32-channel analog to digital 24-bit delta sigma converter card with a PCI express interface. It is implemented using four Cirrus Logic CS5368 8-channel converters. The PCI interface utilizes a PLX Technology PEX-8311AA PCI-express-to-local bus bridge. There is a Lattice ECP2M FPGA for control of board functions including registers and storage. Each converter has an independently selectable clock source generated by a low jitter PLL. The external clocking interface consists of LVDS signaling connected via RJ-25 (6-pin) style cabling.

Features and Characteristics of the DSCC are:

#### 9277 board (CP-AD3224-DS)

- Fully Differential +/-5V
- Differential Input Impedance >200K ohm
- Input Over-Voltage Protection +/-20V

#### 9278 board (CP-AD3224-DS-10)

- Fully Differential +/-10V
- Differential Input Impedance >1Meg ohm
- Input Over-Voltage Protection +/-30V

#### Common to both boards

- 32-channel 24-bit Delta Sigma A to D Conversion.
- Industry Standard SCSI 68-pin Connector for Inputs.
- RJ-12 (6-pin phone style) Connectors for Multi-board Synchronization.
- PCI Express x1 Revision 1.0a.
- Supports MSI Interrupts.
- Independent Clocking for Four Channel Groups.
- Low Jitter Phase Lock Loop (PLL) Clock Generators.
- Supports Multi-board Clocking & Synchronization.
- Directly Addressable Conversion Data Registers.
- 64K Word Conversion Data FIFO with DMA.
- Low Noise Analog Power Generation.
- Positive and Negative Calibration Voltage.
- Gain and Offset Calibration Values Accessible.
- Sampling Rate (Fs) 2Khz to 216Khz.
- NIST Traceable Calibration Standard.
- Non-volatile Storage of Calibration Data & User Configuration.

The board and driver provide support for MSI interrupts. This is the default configuration.

# 2. Requirements

- CCRT-DSCC PCIe board physically installed in the system.
- This driver supports various versions of RedHawk and a selected set of Native Ubuntu and Native Red Hat. Actual supported versions depend on the driver being installed.

### 3. Documentation

- PCIe 32-Channel Delta Sigma Converter Card (DSCC) Software Interface by Concurrent Real-Time.

### 4. Running on Native Red Hat

Though this driver and hardware work best on Concurrent Real-Time **RedHawk** systems, the driver will also be able to run on some selected versions of **Red Hat** with some limitations. Some of these limitations are highlighted below. The rest of the document is applicable to all systems.

When compiling the driver, you may get the following message that can be ignored:

```
Skipping BTF generation for /usr/local/CCRT/drivers/ccurdsc/driver/ccurdsc.ko due to unavailability of vmlinux
```

#### 4.1. Support to build 3<sup>rd</sup> party modules

If your system isn't setup to build 3<sup>rd</sup> party modules, you will need to install some of the following packages if they haven't already been installed before being able to compile the driver. Installation process of these modules may differ from system to system. Refer to the particular system for installation of the modules.

```
# yum install ncurses-devel           (to run curses)
# yum install gnuplot                 (to run plots for various tests)
# yum install <any other package you want to install>
```

#### 4.2. Support for MSI interrupts

- The driver can operate with either MSI or wired interrupts. This is a configuration option that can be selected by editing the `ccurdacc_nomsi` parameter located in the `.../driver/ccurdsc_config` file where the driver is installed. Reloading the driver will cause the MSI interrupt handling option to switch.

- `ccurdsc_nomsi=0` enable MSI support (default for RedHawk systems)
- `ccurdsc_nomsi=1` disable MSI support

Red Hat systems do not have kernel level hooks like CCRT RedHawk systems to enable MSI on a per board basis for cards using a PLX chip for generating interrupts. This is specially true for the later X11SPA-TF SuperMicro Mother boards and onwards. In this case, if the user wishes to use MSI instead of wired interrupts, they can enable them in various ways as outlined below.

- If MSI interrupts are not being generated and the user wishes to continue using MSI interrupts instead of wired interrupts, they can try to resolve the problem by implementing one the following:

- Reload the kernel with the grub option "intremap=nosid"
- Reload the kernel with the grub option "intremap=off"
- Disable VT-d in the BIOS
- Disable VT-d MSI Interrupt Remapping in the BIOS
- Disable 4G Decoding in the BIOS

- To add/remove/display the **intremap** command to grub, issue the following commands:

- `# grubby --update-kernel=ALL --args=intremap=nosid` (add the parameter)

- # grubby --update-kernel=ALL --remove-args=intremap=nosid *(remove the parameter)*
- # grubby --info=ALL *(display parameters)*
- # reboot
- After system reboots, issue the command "**cat /proc/cmdline**" to see if the added entry is present.

### 4.3. BIOS and Kernel Level Tuning

It is possible that some tests may get overflow or underflow errors as the card is capable of high sample rate transfers. You may need to lower the sample rates for these tests to run successfully if BIOS and kernel level tuning does not help.

BIOS tuning for real-time is specific to the mother board where the Red Hat kernel is running. The various BIOS settings need to be studied and changed accordingly to make sure that it is running at optimal performance with minimal interference from other processes.

Some Red Hat kernel level tuning can be performed to see if they are helpful in getting a more real-time performance.

Disable features that allows SCHED\_OTHER tasks to use up to 5% or RT CPUs.

```
sysctl kernel.sched_rt_runtime_us=-1
echo -1 > /proc/sys/kernel/sched_rt_runtime_us
```

Disable timer migration:

```
sysctl kernel.timer_migration=0
echo 0 > /proc/sys/kernel/timer_migration
```

Add following parameters to **/etc/default/grub** line and running **update-grub** and **reboot**.

```
GRUB_CMDLINE_LINUX="skew_tick=1 rcu_nocb_poll rcu_nocbs=1-95 nohz=on nohz_full=1-95
kthread_cpus=0 irqaffinity=0 isolcpus=managed_irq,domain,1-95 intel_pstate=disable
nosoftlockup tsc=nowatchdog"
```

Isolate CPUs e.g *(this command has been officially marked deprecated)*

```
isolcpus=1-8,26-30 rcu_nocbs=1-8,26-30 nohz_full=1-8,26-30 rcu_nocb_poll=1-8,26-30
```

## 5. Running on Native Ubuntu

Though this driver and hardware work best on Concurrent Real-Time **RedHawk** systems, the driver will also be able to run on some selected versions of **Ubuntu** with some limitations. Some of these limitations are highlighted below. The rest of the document is applicable to all systems.

When compiling the driver, you may get the following message that can be ignored:

```
Skipping BTF generation for /usr/local/CCRT/drivers/ccurdsc/driver/ccurdsc.ko due to unavailability
of vmlinux
```

### 5.1. Support to build 3<sup>rd</sup> party modules

If your system isn't setup to build 3<sup>rd</sup> party modules, you will need to install some of the following packages if they haven't already been installed before being able to compile the driver. Installation process of these modules may differ from system to system. Refer to the particular system for installation of the modules.

```
# apt install build-essential
# apt install libssl-dev
# apt install nfs-common (to mount nfs file systems)
# apt install libncurses-dev (to run curses)
# apt install gnuplot (to run plots for various tests)
# apt install chrony (for more accurate clock time)
```

```
# apt install <any other package you want to install>
```

## 5.2. Support for MSI interrupts

- The driver can operate with either MSI or wired interrupts. This is a configuration option that can be selected by editing the `ccurdscn_nomsi` parameter located in the `.../driver/ccurdscn_config` file where the driver is installed. Reloading the driver will cause the MSI interrupt handling option to switch.
  - `ccurdscn_nomsi=0` enable MSI support (*default for RedHawk systems*)
  - `ccurdscn_nomsi=1` disable MSI support
- Red Hat systems do not have kernel level hooks like CCRT RedHawk systems to enable MSI on a per board basis for cards using a PLX chip for generating interrupts. This is specially true for the later X11SPA-TF SuperMicro Mother boards and onwards. In this case, if the user wishes to use MSI instead of wired interrupts, they can enable them in various ways as outlined below.
- If MSI interrupts are not being generated and the user wishes to continue using MSI interrupts instead of wired interrupts, they can try to resolve the problem by implementing one the following:
  - Reload the kernel with the grub option “`intremap=nosid`”
  - Reload the kernel with the grub option “`intremap=off`”
  - Disable VT-d in the BIOS
  - Disable VT-d MSI Interrupt Remapping in the BIOS
  - Disable 4G Decoding in the BIOS
- To add/remove/display the ***intremap*** command to grub, issue the following commands:
  - Edit ***/etc/default/grub*** and add “`intremap=nosid`” to “`GRUB_CMDLINE_LINUX=`” entry
  - `# update-grub`
  - `# reboot`
  - After system reboots, issue the command “***cat /proc/cmdline***” to see if the added entry is present.

## 5.3. Compiling the driver with installed gcc

Depending on the Ubuntu kernel version supported, you will need to make sure that the driver is compiled with the same gcc as the kernel.

Currently, for Ubuntu release 22.04, the kernel 5.15 uses gcc-11 while kernel 6.4 uses gcc-12

If gcc-12 is not installed, you can do the following:

```
# apt install gcc-12
```

Then create alternate entries for each available version:

```
# sudo update-alternatives --install /usr/bin/gcc gcc /usr/bin/gcc-11 11
# sudo update-alternatives --install /usr/bin/gcc gcc /usr/bin/gcc-12 12
```

```
# sudo update-alternatives --install /usr/bin/x86_64-linux-gnu-gcc x86_64-linux-gnu-gcc
/usr/bin/x86_64-linux-gnu-gcc-11 11
```

```
# sudo update-alternatives --install /usr/bin/x86_64-linux-gnu-gcc x86_64-linux-gnu-gcc
/usr/bin/x86_64-linux-gnu-gcc-12 12
```

You can select the appropriate gcc with the following commands:

```
# sudo update-alternatives --config gcc
# sudo update-alternatvies --config x86_64-linux-gnu-gcc
```



All of this will ensure you have the compiler versions that match what the kernel was compiled with.

## 5.4. BIOS and Kernel Level Tuning

It is possible that some tests may get overflow or underflow errors as the card is capable of high sample rate transfers. You may need to lower the sample rates for these tests to run successfully if BIOS and kernel level tuning does not help.

BIOS tuning for real-time is specific to the mother board where the Red Hat kernel is running. The various BIOS settings need to be studied and changed accordingly to make sure that it is running at optimal performance with minimal interference from other processes.

Some Red Hat kernel level tuning can be performed to see if they are helpful in getting a more real-time performance.

Disable features that allows SCHED\_OTHER tasks to use up to 5% or RT CPUs.

```
sysctl kernel.sched_rt_runtime_us=-1
echo -1 > /proc/sys/kernel/sched_rt_runtime_us
```

Disable timer migration:

```
Sysctl kernel.timer_migration=0
echo 0 > /proc/sys/kernel/timer_migration
```

Add following parameters to `/etc/default/grub` line and running **update-grub** and **reboot**.

```
GRUB_CMDLINE_LINUX="skew_tick=1 rcu_nocb_poll rcu_nocbs=1-95 nohz=on nohz_full=1-95
kthread_cpus=0 irqaffinity=0 isolcpus=managed_irq,domain,1-95 intel_pstate=disable
nosoftlockup tsc=nowatchdog"
```

Isolate CPUs e.g (*this command has been officially marked deprecated*)

```
isolcpus=1-8,26-30 rcu_nocbs=1-8,26-30 nohz_full=1-8,26-30 rcu_nocb_poll=1-8,26-30
```

## 6. Installation and Removal

### 6.1. Hardware Installation

The CCRT-DSCC card is a x1 PCI Express product and is compatible with any PCI Express slot. The board must be installed in the system before attempting to use the driver.



***Caution:*** when installing the card insure the computer is powered off and the machine's power cord is disconnected. Please observe electrostatic discharge precautions such as the use of a grounding strap.

---

The **ccurdsc** driver is designed to support IRQ sharing. If this device's IRQ is being shared by another device then this driver's performance could be compromised. Hence, as far as possible, move this board into a PCI slot who's IRQ is not being shared with other devices.

An '**lspci -v**' or the '**lsirq**' command can be used to determine the IRQs of various devices in the system.

```
# lspci -v
```

```
# for 9277 (CP-AD3224-DS) +/- 5 Volt board
```

```
05:04.0 System peripheral: Concurrent Computer Corporation Device 9277
(rev 01)
```

```
Subsystem: PLX Technology, Inc. Device 9056
```

```
Flags: bus master, 66MHz, medium devsel, latency 96, IRQ 98
```

```
Concurrent Real-Time™ ccurdsc Driver for RedHawk Linux™ – Release Notes
```

```
Memory at c4b01000 (32-bit, non-prefetchable) [size=512]
Memory at c4b00000 (32-bit, non-prefetchable) [size=2K]
Capabilities: <access denied>
```

#### # for 9278 (CP-AD3224-DS-10) +/-10 Volt board

```
06:04.0 System peripheral: Concurrent Computer Corporation 10 Volt Delta-
Sigma Input Card (rev 01)
```

```
Subsystem: PLX Technology, Inc. Device 9056
Flags: bus master, 66MHz, medium devsel, latency 96, IRQ 51
Memory at fbbff400 (32-bit, non-prefetchable) [size=512]
Memory at fbbff800 (32-bit, non-prefetchable) [size=2K]
Capabilities: [40] Power Management version 2
Capabilities: [48] #00 [0000]
Capabilities: [4c] Vital Product Data
```

#### # **lsirq**

```
98      05:04.0 Concurrent Computer Corporation Unknown device (rev 01)
```

The default driver configuration uses MSI interrupts. If the kernel supports MSI interrupts, then sharing of interrupts will not occur, in which case the board placement will not be an issue.

After installing the card, reboot the system and verify the hardware has been recognized by the operating system by executing the following command:

```
# lspci -d 1542:9277
# lspci -d 1542:9278
```

For each CCRT-DSCC PCIe board installed, a line like one of the following will be printed, depending on the revision of the system's `/usr/share/hwdata/pci.ids` file:

```
05:04.0 System peripheral: Concurrent Computer Corporation Device 9277 (rev 01)
02:04.0 System peripheral: Concurrent Computer Corporation Device 9278 (rev 01)
```

If a line like the above is not displayed by the `lspci` command, the board has not been properly installed in the system. Make sure that the device has been correctly installed prior to attempting to use the software. One similar line should be found for each installed card.

## 6.2. Add Device to Restricted List

For kernels that have `iommu` enabled, these devices will fail DMA read and write access with a message similar to the following:

```
DMAR: [DMA Read] Request device [1d:00.0] fault addr 5eec0000
[ fault reason 01] Present bit in root entry is clear
```

You can issue the `'cat /proc/cmdline'` command to determine if `iommu` is enabled in the kernel after booting the system. If you see the `'intel_iommu=on'` entry, the kernel has `iommu` enabled for the entire operating system. In this case you will need to restrict `iommu` usage for these devices.

To enable DMA to work, you will need to add the following entries to the kernel grub line:

1. `iommu=pt` *(this passthrough option is needed for restricting the selected devices)*
2. `intel_iommu.blacklist_ids=1542:9277` *(vendor:device id if 9277 card is installed)*
3. `intel_iommu.blacklist_ids=1542:9278` *(vendor:device id if 9287 card is installed)*
4. `intel_iommu.blacklist_ids=1542:9277,1542:9278` *(vendor:device id if both cards are installed)*

Use the `ccur-grub2` or `blscfg` command depending on the loaded kernel. You can use the following argument `'--help'` to either command for additional information on its usage.

1. `ccur-grub2 --kopt-add iommu=pt 0,1,2` (for kernel entries 0, 1 and 2)
2. `ccur-grub2 --kopt-add intel_iommu.blacklist_ids=1542:9277,1542:9278 0,1,2`

Reboot the kernel for the device restriction to take effect. You should get a message similar to the one below if the command took effect:

```
DMAR: add [1542:9277] to intel_iommu blacklist
DMAR: add [1542:9278] to intel_iommu blacklist
```

Note!!!

If you wish to disable *iommu* for all devices under a PLX bridge you can use the following option instead:

1. `intel_iommu=on,plx_off`

If you want DMA to work for kernels that do *not* support *plx\_off* or *intel\_iommu.blacklist\_ids* you will need to disable *iommu* in the kernel.

1. `intel_iommu=off`

## 6.3. Software Installation

Concurrent Real-Time™ port of the **ccurdscc** software is distributed in RPM and DEB format on a DVD. Source for the API library, example test programs, and kernel loadable driver are included, as is documentation in PDF format.

The software is installed in the `/usr/local/CCRT/drivers/ccurdscc` directory. This directory will be referred to as the “top-level” directory by this document.



**Warning:** Before installing the software, for RedHawk kernels, the build environment **must** be set up and match the current OS kernel you are using. If you are running one of the preconfigured kernels supplied by Concurrent Real-Time and have not previously done so, run the following commands while logged in as the root user before installing the driver software:

```
# cd /lib/modules/`uname -r`/build
# ./ccur-config -c -n
```

If you have built and are running a customized kernel configuration the kernel build environment should already have been set up when that custom kernel was built.

---

To install the **ccurdscc** package, load the DVD installation media and issue the following commands as the **root** user. The system should auto-mount the DVD to a mount point in the `/media` or `/run/media` directory based on the DVD's volume label – in this case **ccurdscc\_driver**. The example's `[user_name]` may be **root**, or the logged-in user. Then enter the following commands from a shell window:

```
== as root ==
--- on RedHawk 6.5 and below ---
# cd /media/ccurdscc_driver
--- or on RedHawk 7.0 and above ---
# cd /run/media/[user_name]/ccurdscc_driver
--- or on Ubuntu RedHawk ---
# cd /media/[user_name]/ccurdscc_driver

# rpm -ivh ccurdscc_RedHawk_driver*.rpm (on an RPM based system)
--- or ---
# dpkg -i ccurdscc_RedHawk_driver*.deb (on a Debian based system)
```

```
# cd /
# eject
```

On successful installation the source tree for the **ccurdscc** package, including the loadable kernel module, API libraries, and test programs is extracted into the **/usr/local/CCRT/drivers/ccurdscc** directory by the rpm installation process, which will then compile and install the various software components.

The loadable kernel module is installed in the **/lib/modules/`uname -r`/misc** directory. Issue the command below to view the boards found by the driver:

```
# cat /proc/ccurdscc

Version          : 23.0.1
Built           : Mon Jun 4 2018, 10:25:49
Boards          : 1
  card=0: [0f:04.0] bus=15, slot=4, func=0, irq=105, msi=1, nbuf=10, hwm=0, ID=656739,
BoardInfo=0x92780202

DMA Memory: (Allocated): card number(s): 0
```

Once the package is installed, the driver needs to be loaded with one of the following commands:

```
=== as root ===
# cd /usr/local/CCRT/drivers/ccurdscc
# make load
  --- or on RedHawk 6.5 and below ---
# /sbin/service ccurdscc start
  --- or on RedHawk 7.0 and above ---
# /usr/bin/systemctl start ccurdscc
  --- or on Ubuntu RedHawk ---
# /bin/systemctl start ccurdscc
```

When the driver is loaded with the `/sbin/service` or `/usr/bin/systemctl` call, automatic calibration will commence for all the cards installed in the system and run in the background. This is also true when the system is rebooted. Issuing the 'make load' in the driver directory will *not* initiate an automatic calibration.

## 6.4. Software Removal

The **ccurdscc** driver is a dynamically loadable driver that can be unloaded, uninstalled and removed. Once removed, the only way to recover the driver is to re-install the **rpm** from the installation DVD:



If any changes have been made to the driver package installed in **/usr/local/CCRT/drivers/ccurdscc** directory, they need to be backed up prior to invoking the removal; otherwise, all changes will be lost.

---

```
=== as root ===
# rpm -e ccurdscc (driver unloaded, uninstalled, and deleted – on an RPM based system)
  --- or ---
# dpkg -P ccurdscc (driver unloaded, uninstalled, and deleted – on a Debian based system)
```

If, for any reason, the user wishes to un-load and uninstall the driver and not remove it, they can perform the following:

```
=== as root ===
# cd /usr/local/CCRT/drivers/ccurdscc
# make unload (unload the driver from the kernel)
  --- or on RedHawk 6.5 and below ---
# /sbin/service ccurdscc stop
  --- or on RedHawk 7.0 and above ---
```

```
# /usr/bin/systemctl stop ccurdscc
   --- or on Ubuntu RedHawk ---
# /bin/systemctl stop ccurdscc
```

To uninstall the **ccurdscc** driver, do the following after it has been unloaded:

```
=== as root ===
# cd /usr/local/CCRT/drivers/ccurdscc
# make uninstall      (uninstall the driver and library)
```

In this way, the user can simply issue the **'make install'** and **'make load'** in the **/usr/local/CCRT/drivers/ccurdscc** directory later to re-install and re-load the driver.

## 7. Auto-loading the Driver

The **ccurdscc** driver is a dynamically loadable driver. Once you install the package or perform the **'make install'**, appropriate installation files are placed in the **/etc/rc.d/rc\*.d** or **/usr/lib/systemd/systemd** directory so that the driver is automatically loaded and unloaded when Linux is booted and shutdown. If, for any reason, you do not wish to automatically load and unload the driver when Linux is booted or shutdown, you will need to manually issue the following command to enable/disable the automatic loading of the driver:

```
=== as root ===
   --- on RedHawk 6.5 and below ---
# /sbin/chkconfig --add ccurdscc      (enable auto-loading of the driver)
# /sbin/chkconfig --del ccurdscc     (disable auto-loading of the driver)
   --- or on RedHawk 7.0 and above ---
# /usr/bin/systemctl enable ccurdscc  (enable auto-loading of the driver)
# /usr/bin/systemctl disable ccurdscc (disable auto-loading of the driver)
   --- or on Ubuntu RedHawk ---
# /bin/systemctl enable ccurdscc      (enable auto-loading of the driver)
# /bin/systemctl disable ccurdscc     (disable auto-loading of the driver)
```

## 8. Testing and Usage

Build and run the driver test programs, if you have not already done so:

```
# cd /usr/local/CCRT/drivers/ccurdscc
# make test      (build the test programs)
Several tests have been provided in the /usr/local/CCRT/drivers/ccurdscc/test directory and can be run to test the driver and board.
```

```
=== as root ===
# ./test/ccurdscc_disp      (display channel data)
# ./test/ccurdscc_dump     (dump board registers)
# ./test/ccurdscc_get_sps  (determine sample rate for the channels)
# ./test/ccurdscc_rdreg    (display board resisters)
# ./test/ccurdscc_reg      (Display board resisters)
# ./test/ccurdscc_regedit  (Interactive board register editor test)
# ./test/ccurdscc_tst      (Interactive test to test driver and board)
# ./test/ccurdscc_wreg     (edit board resisters)
# ./test/lib/ccurdscc_calibrate (library: get/set board calibration)
# ./test/lib/ccurdscc_compute_pll_clock (library: compute pll clock)
# ./test/lib/ccurdscc_disp  (library: display channel data)
# ./test/lib/ccurdscc_dma_read (library: simple driver DMA read)
# ./test/lib/ccurdscc_fifo  (library: perform FIFO reads)
```

```
# ./test/lib/ccurdscc_identify      (library: identify board)
# ./test/lib/ccurdscc_smp_affinity (library: display/set IRQ CPU affinity)
# ./test/lib/ccurdscc_tst_lib      (library: Interactive test to test driver and board)
# ./test/lib/sprom/ccurdscc_sprom  (library: serial prom view/update calibration utility)
```

## 9. Re-building the Driver, Library and Tests

If for any reason the user needs to manually rebuild and load an *installed rpm* package, they can go to the installed directory and perform the necessary build.



**Warning:** Before installing the software, for RedHawk kernels, the build environment **must** be set up and match the current OS kernel you are using. If you are running one of the preconfigured kernels supplied by Concurrent Real-Time and have not previously done so, run the following commands while logged in as the root user before installing the driver software:

```
# cd /lib/modules/`uname -r`/build
# ./ccur-config -c -n
```

If you have built and are running a customized kernel configuration the kernel build environment should already have been set up when that custom kernel was built.

---

To build the driver and tests:

```
=== as root ===
# cd /usr/local/CCRT/drivers/ccurdscc
# make clobber      (perform cleanup)
# make              (make package and build the driver, library and tests)
(Note: if you only wish to build the driver, you can enter the 'make driver' command instead)
```

After the driver is built, you will need to install the driver. This install process should only be necessary if the driver is re-built with changes.

```
=== as root ===
# cd /usr/local/CCRT/drivers/ccurdscc
# make install      (install the driver software, library and man page)
```

Once the driver and the board are installed, you will need to **load** the driver into the running kernel prior to any access to the CCURDSCC board.

```
=== as root ===
# cd /usr/local/CCRT/drivers/ccurdscc
# make load         (load the driver)
```

## 10. Software Support

This driver package includes extensive software support and test programs to assist the user in communicating with the board. Refer to the *Concurrent Real-Time PCIe 32-Channel Delta Sigma Converter Card (DSCC) Software Interface* document for more information on the product.

### 10.1. Device Configuration

After the driver is successfully loaded, the device to card association file ***ccurdscs\_devs*** will be created in the ***/usr/local/CCRT/drivers/ccurdscs/driver*** directory, if it did not exist. Additionally, there is a symbolic link to this file in the ***/usr/lib/config/ccurdscs*** directory as well. If the user wishes to keep the default one-to-one device to card association, no further action is required. If the device to card association needs to be changed, this file can be edited by the user to associate a particular device number with a card number that was found by the driver. The commented portion on the top of the ***ccurdscs\_devs*** file is automatically generated every time the user issues the ***'make load'***, ***'/sbin/service ccurdscs start'*** (on RedHawk 6.5 and below), or ***'systemctl start ccurdscs'*** (on RedHawk 7.0 and above) command with the current detected cards, information. Any device to card association edited and placed in this file by the user is retained and used during the next ***'make load'***, ***'/sbin/service ccurdscs start'*** or ***'systemctl start ccurdscs'*** process.

If the user deletes the ***ccurdscs\_devs*** file and recreates it as an empty file and performs a ***'make load'*** or if the user does not associate any device number with card number, the driver will provide a one to one association of device number and card number. For more information on available commands, view the commented section of the ***ccurdscs\_devs*** configuration file.



***Warning:*** If you edit the ***ccurdscs\_devs*** file to associate a device to a card, you will need to re-issue the ***'make load'***, ***'/sbin/service ccurdscs start'***, or ***'systemctl start ccurdscs'*** command to generate the necessary device to card association. This device to card association will be retained until the user changes or deletes the association. **If any invalid association is detected, the loading of the driver will fail.**

---

## 10.2. Library Interface

There is an extensive software library that is provided with this package. For more information on the library interface, please refer to the *PCIe 32-Channel Delta Sigma Converter Card (DSCC) Software Interface by Concurrent Real-Time* document.

## 10.3. Calibration

Several library calls are provided to assist the user in calibrating the board. Additionally, the board contains factory calibration information for the output voltage range. Users can view this information using the supplied API or the serial prom test utility *ccurdscs\_sprom*. Though the API and test utility provides capability to edit and change the factory calibration, users should refrain from making any changes to it, as it will no longer reflect the factory calibration shipped with the card. Users can use the factory calibration to restore the calibration information stored for each configured channel prior to commencing a test run. The restore API will update the calibration information for all the channels based on their current voltage range. Note that the factory calibration values were obtained under specific conditions, such as temperature, that may not be the same as the user application. In most cases it will always be better to perform auto-calibration after the board is stabilized in the user environment.

Additionally, the users can perform up to two independent user controlled checkpoints where the active channel configuration and calibration information is stored in the serial prom for all the channels. At any time, the user can restore either of the two checkpoints with an API call or the serial prom test utility *ccurdscs\_sprom* prior to a test run. These checkpoints will allow the user to store specific values pertaining to their calibration conditions.

## 10.4. Firmware Updates

This board is capable of being re-programmed in the field as new firmware updates are made available by *Concurrent Real-Time™*. The procedure for re-programming the firmware will be supplied to the user at the time when a firmware update is necessary.

## 10.5. Debugging

This driver has some debugging capability and should only be enabled while trying to trouble-shoot a problem. Once resolved, debugging should be disabled otherwise it could adversely affect the performance and behavior of the driver.

To enable debugging, the **Makefile** file in **/usr/local/CCRT/drivers/ccurdsc/driver** should be edited to un-comment the statement (*remove the preceding '#'*):

```
#BUILD_TYPE=debug
```

Next, compile and install the driver

```
# cd /usr/local/CCRT/drivers/ccurdsc/driver
# make
# make install
```

Next, edit the **ccurdsc\_config** file in **/usr/local/CCRT/drivers/ccurdsc/driver** to un-comment the statement (*remove the preceding '#'*):

```
# ccurdsc_debug_mask=0x00002040
```

Additionally, the value of the debug mask can be changed to suite the problem investigated. Once the file has been edited, the user can load the driver by issuing the following:

```
# cd /usr/local/CCRT/drivers/ccurdsc/driver
# make load
```

The user can also change the debug flags after the driver is loaded by passing the above debug statement directly to the driver as follows:

```
# echo "ccurdsc_debug_mask=0x00082047" > /proc/driver/ccurdsc
```

Following are the supported flags for the debug mask as shown in the **ccurdsc\_config** file.

```
#####
#
#      D_ENTER      0x00000001 /* enter routine */
#      D_EXIT      0x00000002 /* exit routine */
#
#      D_L1        0x00000004 /* level 1 */
#      D_L2        0x00000008 /* level 2 */
#      D_L3        0x00000010 /* level 3 */
#      D_L4        0x00000020 /* level 4 */
#
#      D_ERR       0x00000040 /* level error */
#      D_WAIT      0x00000080 /* level wait */
#
#      D_INT0      0x00000100 /* interrupt level 0 */
#      D_INT1      0x00000200 /* interrupt level 1 */
#      D_INT2      0x00000400 /* interrupt level 2 */
#      D_INT3      0x00000800 /* interrupt level 3 */
#      D_INTW      0x00001000 /* interrupt wakeup level */
#      D_INTE      0x00002000 /* interrupt error */
#
#      D_RUNTIME   0x00010000 /* display read times */
#      D_WTIME     0x00020000 /* display write times */
#      D_REGS      0x00040000 /* dump registers */
#      D_IOCTL     0x00080000 /* ioctl call */
#
#      D_DATA      0x00100000 /* data level */
#      D_DMA       0x00200000 /* DMA level */
#
```



```

#         D_DBUFF          0x00800000  /* DMA buffer allocation */           #
#
#         D_NEVER          0x00000000  /* never print this debug message */   #
#         D_ALWAYS        0xffffffff  /* always print this debug message */   #
#         D_TEMP           D_ALWAYS    /* Only use for temporary debug code */ #
#####

```

Another variable *ccurdscc\_debug\_ctrl* is also supplied in the *ccurdscc\_config* that the driver developer can use to control the behavior of the driver. The user can also change the debug flags after the driver is loaded by passing the above debug statement directly to the driver as follows:

```
# echo "ccurdscc_debug_ctrl=0x00001234" > /proc/driver/ccurdscc
```

To make use of this variable, the driver must be coded to interrogate the bits in the *ccurdscc\_debug\_ctrl* variable and alter its behavior accordingly.

## 11. Notes and Errata

- In some kernel releases, when a package is installed or uninstalled, you may see a warning message on the system console similar to “**systemd-rc-local-generator[22094]: /etc/rc.d/rc.local is not marked executable, skipping.**”. This is for informational purpose only and can be ignored.
- If a kernel is configured with the CONFIG\_DEBUG\_LOCK\_ALLOC define, the driver will fail to compile due to mutex\_lock\_nested() call being included with GPL requirement. If you want to successfully compile the driver, you will need to remove the CONFIG\_DEBUG\_LOCK\_ALLOC define and rebuild the kernel.
- Ubuntu kernels RH8.0 onwards may have the default **systemd-timesyncd** daemon installed which does not accurately adjust the system. You may want to replace the default with the **chrony** package for a more accurate time adjustment.
- The 9277 board comes in +/5 Volt range.
- The 9278 board comes in +/-10 Volt range.
- Full differential mode is supported by these boards.
- When synchronizing multiple cards, only one synchronization clock can be selected even though the board supports multiple clocks.
- Driver and board supports MSI interrupts. The default configuration is to perform MSI interrupts.
- On some kernel logs, you may see warnings about module verifications and tainted kernel. These can be ignored as they are generated due to the fact that this is a proprietary driver.
- Some new SuperMicro Mother Boards (X11SPA-TF) have a problem with supporting MSI interrupts on these cards. The driver detects this problem and attempts to switch to alternate MSI support. If that also fails, then wired interrupts configured by the driver. If the board detects this issue, an appropriate error message is inserted in the kernel log message (which can be viewed with the command *dmesg*).
- On some SuperMicro Mother Boards, if the BIOS has enabled VT-d MSI interrupt remapping, there is a problem with some kernels where interrupts will not be generated due to source-id verification failure. Currently, the driver has implemented hooks into the RedHawk 6.5 onwards kernels to fix this problem.
- If MSI interrupts are not being generated and the user wishes to continue using MSI interrupts instead of wired interrupts, they can try to resolve the problem by implementing one the following:
  - Reload the kernel with the grub option “intremap=nosid”
  - Reload the kernel with the grub option “intremap=off”
  - Disable VT-d in the BIOS
  - Disable VT-d Msi Interrupt Remapping in the BIOS
  - Disable 4G Decoding in the BIOS

# Appendix A: External Connections and Pin-outs

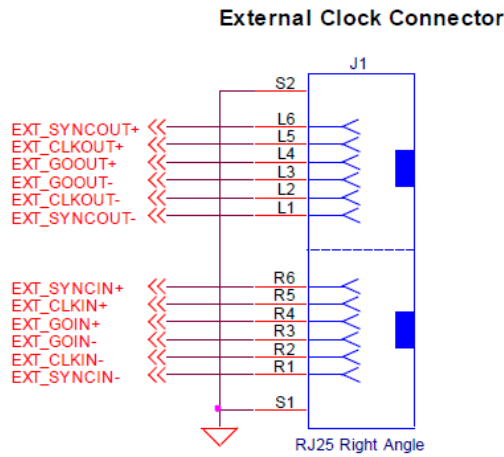
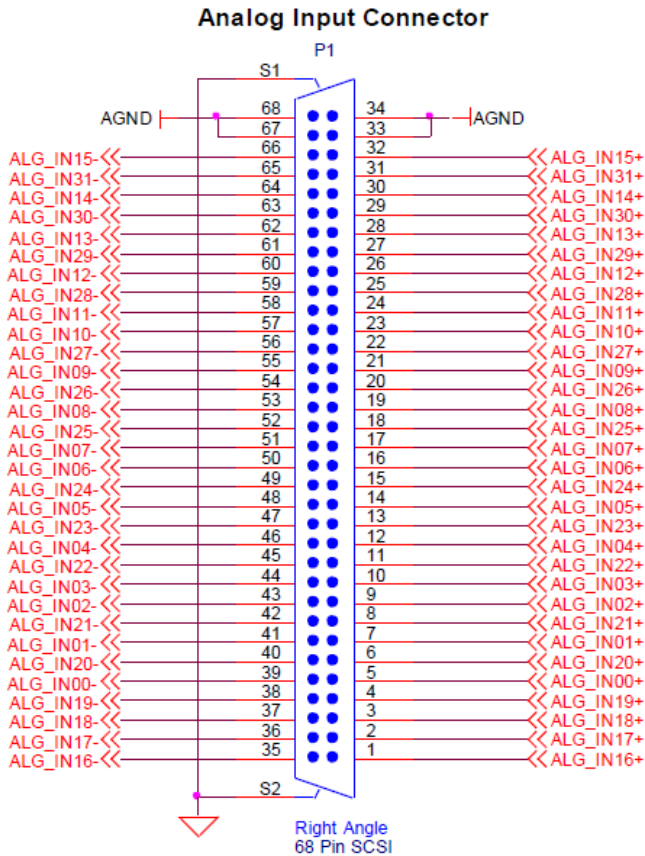

## Appendix B: The 9277 (CP-AD3224-DS) +/- 5 Volt Board

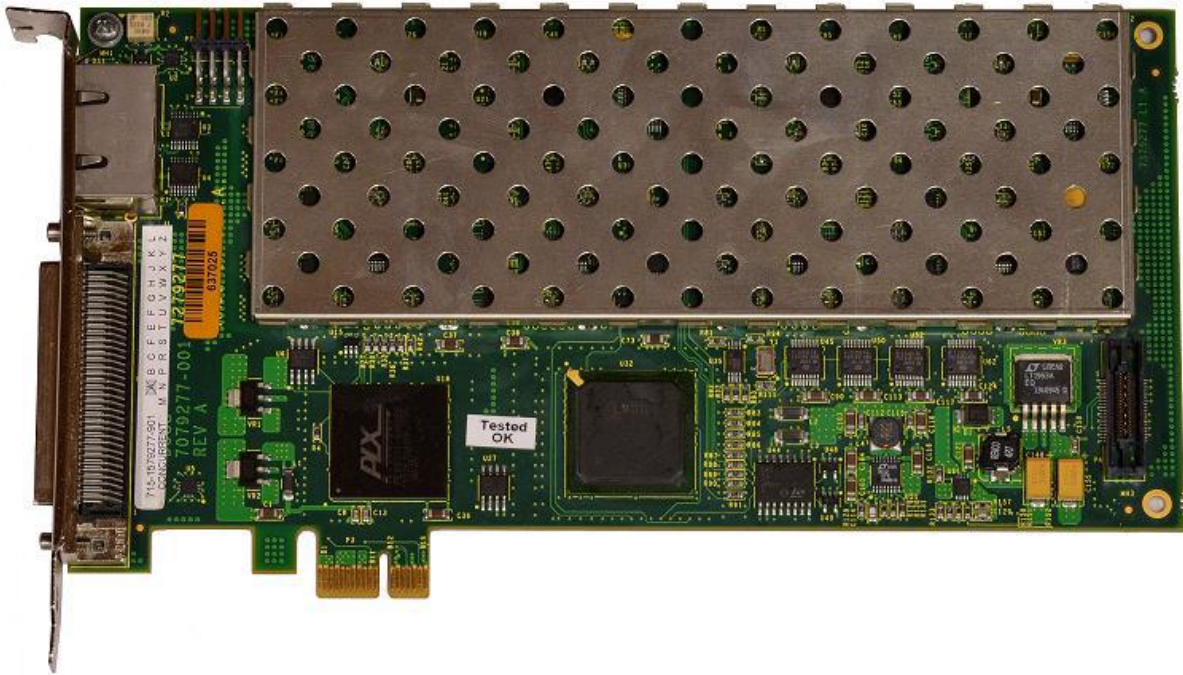

## Appendix C: The 9278 (CP-AD3224-DS-10) +/- 10 Volt Board

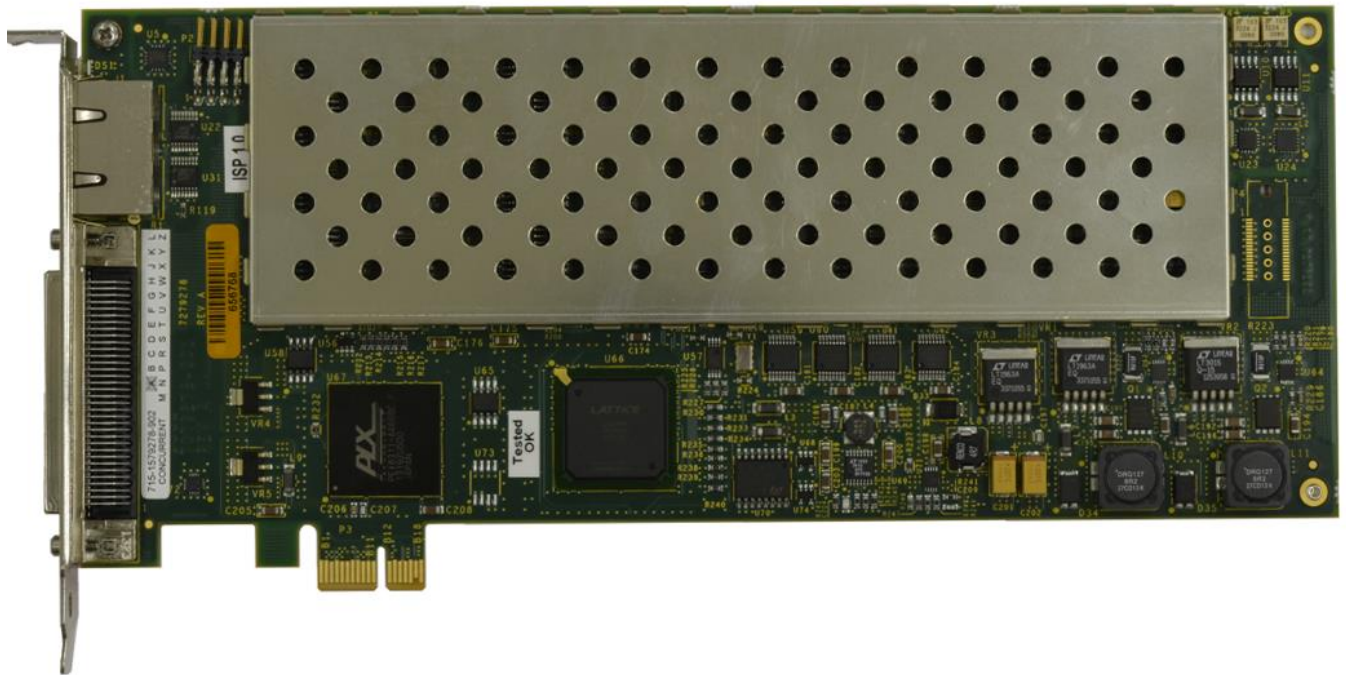

*This page intentionally left blank*